



GOLDEN
Elegant lighting for everyday living

PARTS & ASSEMBLY SHEET









Fixture Name: Lancaster 6005-BA4 PW/RBZ/AB

This fixture assembled PO: _____ Date: _____

Notice: Please review the parts listing and check for all parts before assembling the fixture. If any parts are missing or damaged, please note on this sheet and contact the place of purchase to arrange for replacement parts.

PARTS LIST

Company Name: _____ Co. Account #: _____
below to be filled out by retailer

Mounting Strap  1ea 4" X 3"	Junction Box Screw  2ea 8/32" X 1"	Mounting Screw  2ea 5/32" X 28mm
Wire Connector  2ea P2 Orange	Hex Nut  2ea 5/32" X 3.5mm	Deco Nut (round nut)  2ea 9 X 9.5mm
Green Ground Screw  1ea 8/32" X 10mm	Socket Ring (AB only)  4ea 51 x 23mm	Socket Ring (PW, RBZ only)  4ea 50 x 9mm
Part Needed _____	Quantity _____	
Part Needed _____	Quantity _____	
Reason why _____ (missing, scratched, broken glass, bent, bad finish)		
Comments _____		

FIXTURE ASSEMBLY INSTRUCTIONS

Read and review installation instruction sheet before assembling the fixture.

- Slide the Glass Shade (H) over Socket (I). Secure Glass Shade (H) by threading the Socket Ring (J) to Socket (I).
- Repeat step 1 for remaining glass shades.
- Install light bulbs in accordance with fixture's specifications.

(DO NOT EXCEED THE MAXIMUM WATTAGE RATING!)

NOTE: INSTALL THE GLASS ASSEMBLY AFTER THE FIXTURE IS HUNG.

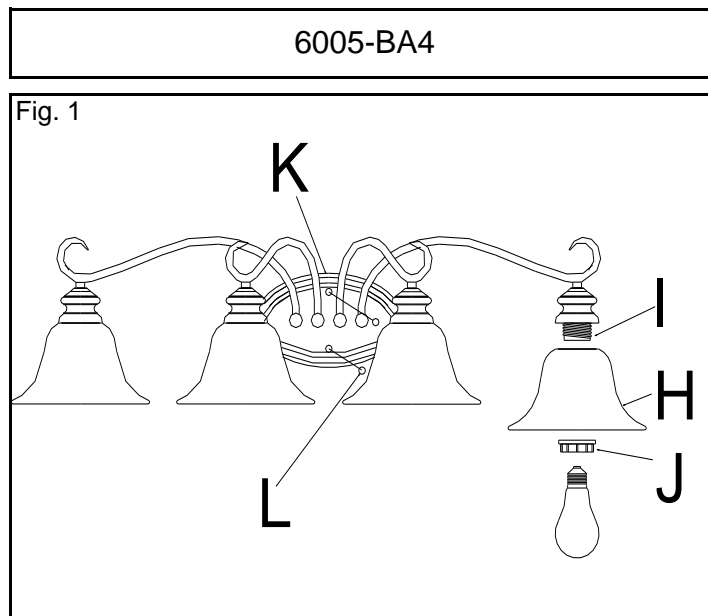

For Customer Service, contact the place of purchase to arrange for replacement parts.

WARNING ! SHUT OFF POWER AT FUSE OR CIRCUIT BREAKER.

HANGING THE FIXTURE (Fig. 1)

1. Carefully remove the new fixture from the carton and the yellow bag that holds all your parts. Check that all parts are included as shown in the illustration and parts list.
2. Shut off power at the circuit breaker and remove the old fixture from wall, including the old mounting strap.
3. The Mounting Strap (A) contains several pairs of threaded holes. Find the pair of holes that match the hole spacing in your fixture Back Plate (K). Thread the two Mounting Screws (B) halfway into the Mounting Strap (A).
4. Place the Mounting Strap (A) over the Junction Box (E) so the Mounting Screws (B) are horizontal.
5. Attach the Mounting Strap (A) to the Junction Box (E) by using the two mounting screws (D). Tighten the screws securely.

Fig. 1

JUNCTION BOX

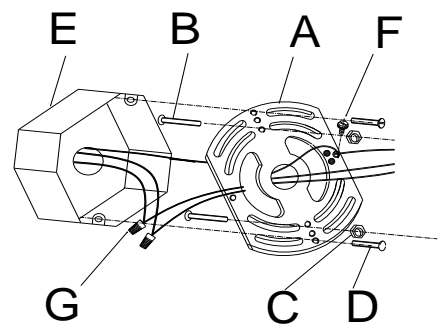

CONNECTING THE WIRES (Fig. 2)

6. Attach the power supply wires to the fixture lead wires by connecting BLACK to BLACK (or SMOOTH) and WHITE to WHITE (or RIBBED).
- NOTE: Twist the wires together in the same direction you twist the wire connector onto the wires.
7. Attach the GROUND wire (GREEN or COPPER) from the junction box and the fixture ground wire to the green ground screw on the Mounting Bracket (A). Or, connect both wires together using a wire connector.
 8. Tuck these wire connections neatly into the junction box.

Fig. 2

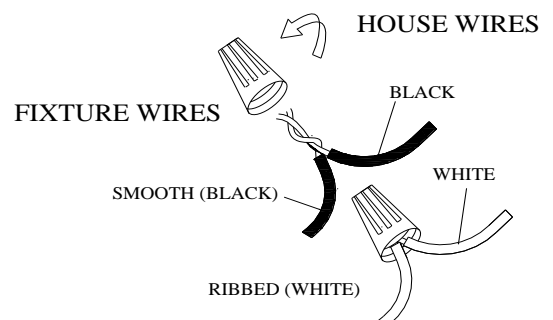

FINISHING THE INSTALLATION (Fig. 3)

9. Place the fixture Back Plate (K), over the Mounting Screws (B), so they protrude through the holes in the Back Plate (K).
10. Thread the Deco Nuts (L) onto the Mounting Screws (B) and continue turning until the Back Plate (K) is snug against the wall.
11. Install glass according to the fixture assembly instructions.

Fig. 3

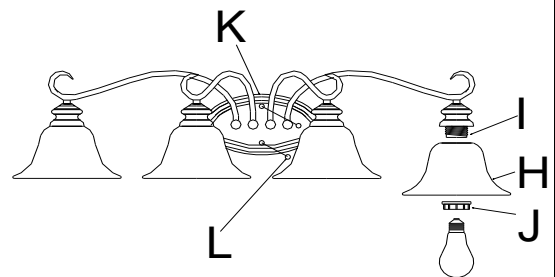

YOUR INSTALLATION IS NOW COMPLETE. RETURN POWER TO THE JUNCTION BOX AND TEST THE FIXTURE.